



FITTING INSTRUCTIONS FOR

# Rear Door Table & Door Cards

SKU

**KS0715**

COMPATIBILITY

**Toyota LandCruiser 70 Series Wagon & Troopcarrier**

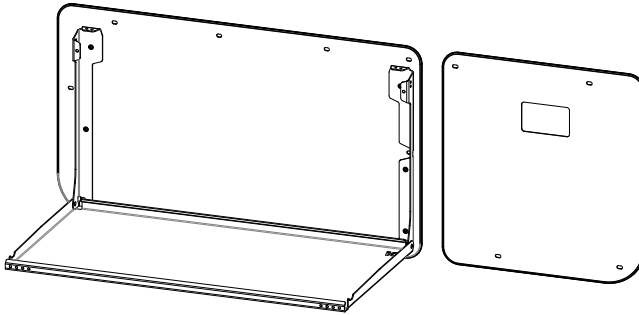

## Included contents

QTY	COMPONENT	QTY	COMPONENT
2	Replacement Door Cards (LHS & RHS)	2	Paracord 670mm
2	Table Brackets (LHS & RHS)	2	Bungee Button
1	Rear Door Table	2	M5 x 16 Button Head Socket Screw
14	M5 x 25 Countersunk Socket Screw	2	M5 Nyloc Nut
28	M5 Dress Washer	5	M5 x 15 x 1.2 DIN Flat Washer
1	M5 Nutsert Tool	2	M8 x 16 Button Head Socket Screw
14	M5 Nutsert	2	M8 x 17 x 1.2 Washer
5	M5 x 6 Button Head Socket Screw	2	M8 Nyloc Nut

 <b>Time</b>	45 minutes / One beer
---	-----------------------

Scan the **QR code** to watch the video installation guide,  
or for further information contact KAON on **07 3180 1470** or **info@kaon.com.au**



# Let's get to work.

## Preparing the Rear Doors

1. Using a plastic trim tool, first remove the large door card by gently prying the card from the rear door.
2. For the small door card, first remove the small screw in the handle using a screwdriver.
3. To remove the handle, first push it towards the front of the vehicle. The handle should pop free of the trim.
4. Undo the small clip on the handle mechanism by pulling it towards yourself. The handle should then be able to be removed by pulling it downwards.
5. Repeat step 1 with the small door.
6. Keep the handle and screw on hand for later. Set aside the door cards, we won't be needing them.

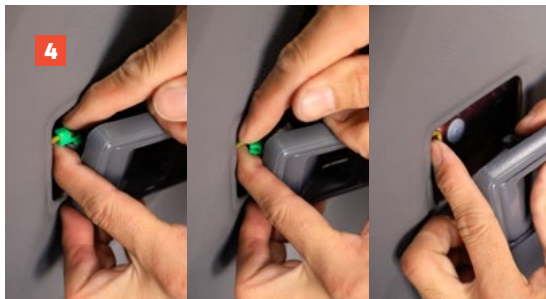

## Nutserting the Rear Doors

7. We need to install M5 nutserts into the existing holes from the original trim clips.
8. On the large right hand side door we will be nutserting all the trim clip holes, as pictured.
9. On the small left hand side door we will be nutserting the four outside corners, as pictured. **Do not** nutsert the other holes.
10. If you have a nutsert gun, use it to install the nutserts. Otherwise, set up the nutsert on the provided nutsert tool using an allen key and a ring spanner, as pictured. Apply a small dab of grease to the threaded bolt on the nutsert tool, reapply as necessary.
11. Set the nutsert into the hole and tighten until you feel that it has clamped onto the vehicle.
12. Once set, remove the bolt and nut, leaving the nutsert in the rear door.
13. Repeat for the remaining holes outlined above.

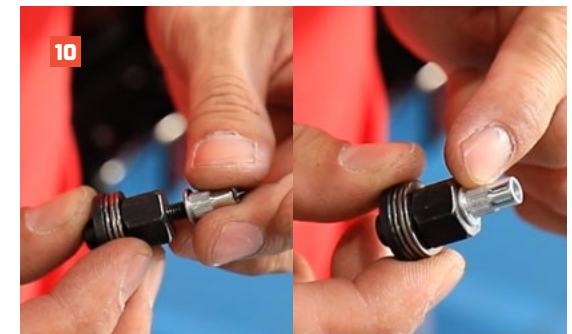
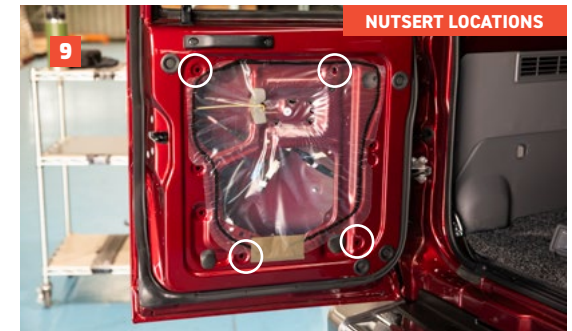
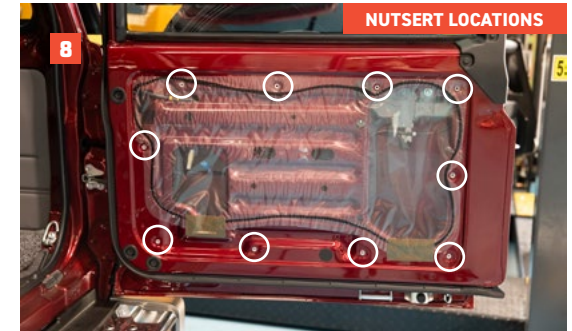

## Preparing the Door Cards

14. Place the large replacement door card on a flat surface, with the raised threaded mounts protruding upwards, and the cards rolled edges facing downwards.

15. Loosely and carefully install the table brackets to the threads using the M5 bolts and washers, **ensuring not to cross-thread or over-tighten the bolts**. Ensure the brackets are in the correct orientation and on the correct sides, they should sit perfectly over the raised threads.

The left hand side bracket only requires the top two bolts. The lower mounting hole will be secured with the bolt that holds the card to the door.

16. Pull the bracket as far to the outsides as possible and secure. If needed, we can adjust the brackets once the table is installed.

17. Prepare all the countersunk mounting bolts with the provided dress washers.

18. Thread the countersunk bolts with washers through the mounting holes of both the large and small replacement door cards. Place another dress washer on the back of each bolt. This secondary washer will act as a spacer in the recessed mounts, and will hold itself in place.

Ensure you pass the lower left hand side bolt of the large door card through both the card and the table bracket.

19. **Optional:** Now is the best time to add any optional pieces to the small door card, such as a Storage Pod. The door cards are aluminium, so are easily drilled to be customised for additional accessories. Ensure your rear setup has sufficient clearance first.

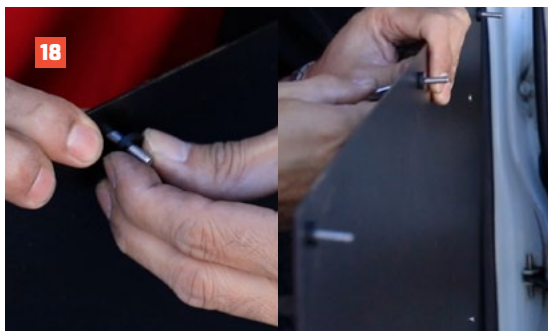
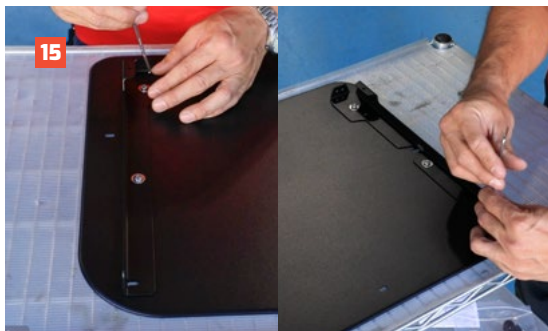

## Installing the Door Cards

20. Position the large replacement door card on the large door, start by loosely installing the top center bolt to the nutsert, then repeat this for the remaining bolts. The pre-installed bolts on the door card should align, but if required can be guided into position with a gentle nudge behind the card.

21. With the center bolt loosely installed, the card should self-support while you loosely install all the remaining bolts.

22. With all the bolts loosely installed, check the door card position for even alignment and adjust if necessary. With the position confirmed, tighten the mounting bolts.

23. Reinstall the handle to the small door by threading the wire into the handle, and sliding the clip across to secure.

24. Thread the handle sideways through the opening in the small door card, taking care with the bolt threads on the rear. Once the handle is through the opening, twist the card to get it into its final position.

25. With the door card aligned, install all four corner mounts to the nutserts in the door.

26. With the bolts installed, push the handle into its opening and slide to left until the screw hole in the handle lines up with the thread behind. Reinstall the screw with a screwdriver.

27. Check the door card position for even alignment, and adjust if necessary. With the position confirmed, tighten the mounting bolts.

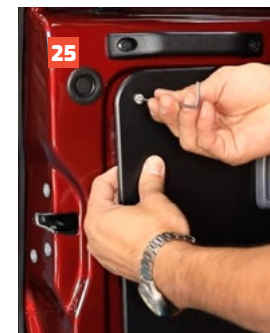
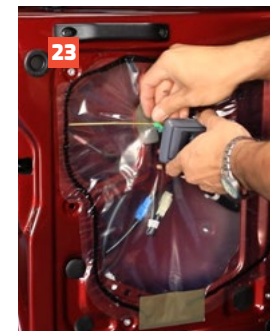

## Installing the Table

28. Attach the table to the LHS bracket using the M8 button head screw and M8 round washer and tighten with the M8 nyloc nut. Ensure the table sits on the outside of the bracket and the washer is between the table and the bracket.
29. Repeat the process for the RHS table bracket.

### **If you are also installing the**

### **Kitchenette Clip-In Sink Extension:**

Sandwich the supplied tab bracket between the washer and table on the RHS. Position the tab bracket so the holes line up and the tab bracket hangs over the right-hand side of the table, as pictured.

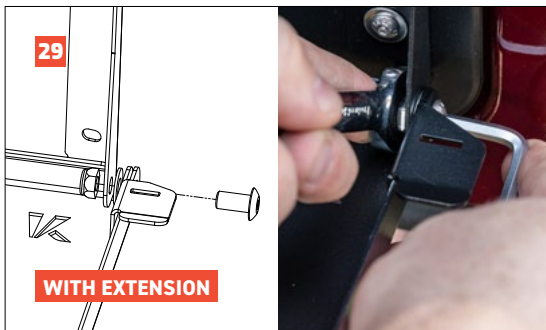
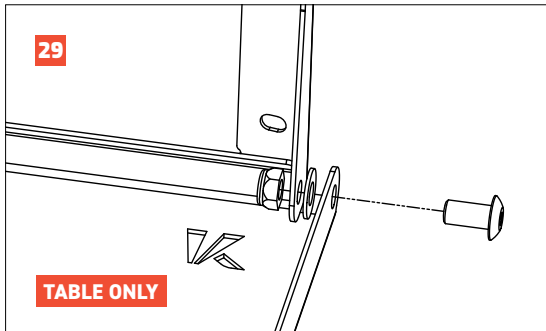

## Installing the Table cont.

30. To attach the support line at the tops of the brackets, weave the cord through the holes and tie a basic knot to secure.
31. To attach the support line to the table, weave the cord through the holes of table as shown. This allows the table level to be easily adjusted, while remaining secure. Repeat on other side.
32. With the support lines in place, confirm the positioning of both the table and table brackets, and tighten all bolts. The table hinge can be tightened to suit the desired friction.
33. To install the bungee buttons, on each side place the M5 button head screw through the front of the button, and secure to the front of the table with the washer nyloc nut.
34. That's it! We're all done – your new table is ready to go!
35. If you're installing a Kitchenette Clip-In Sink Extension or a Clip-In Chopping Board, now's the time to refer to the instructions provided with them.

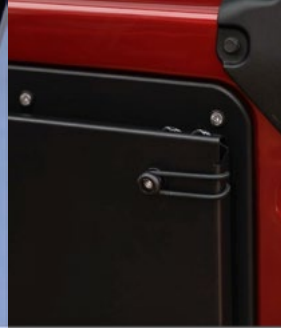
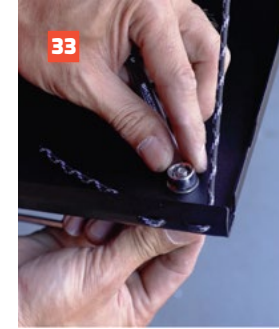
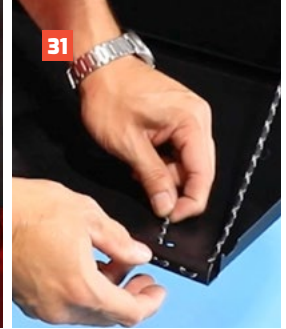
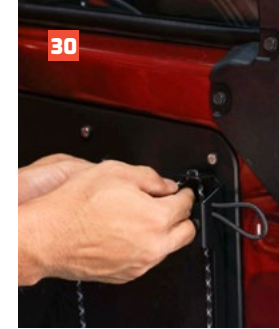



## **Local Knowledge & Assistance**

We know half the fun of building your dream 4x4 is getting your hands dirty. But we also know that sometimes, things don't go to plan. If in the pursuit to build the ultimate setup you find yourself off-track, we're here to help you get unstuck.

**For further information call 07 3180 1470 or email [info@kaon.com.au](mailto:info@kaon.com.au)**

Disclaimer: The products sold by KAON should not be modified, and are for use only on the vehicles specifically stated. KAON will not be liable for any damages arising out of the use or misuse of its products. It is the customers responsibility to ensure the products are safely and properly used and installed. KAON consistently seeks to improve its products and reserves the right to make changes to any product.