



FITTING INSTRUCTIONS FOR

Light Cargo Barrier

SKU

KS0644

COMPATIBILITY

Nissan Patrol Y62

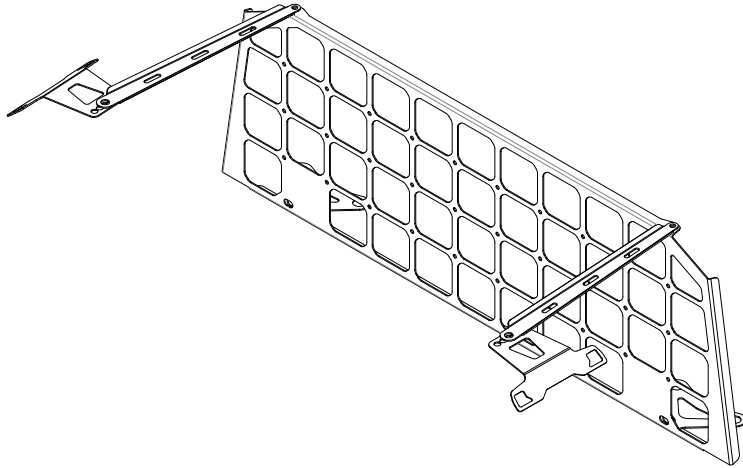

Included contents

QTY	COMPONENT	QTY	COMPONENT
1	Light Cargo Barrier	2	M10 x 20 Black Plastic Knob
2	Barrier Bracket	2	M6 X 18 X 1.6 DIN Flat Washer
2	Handle Bracket	2	M10 x 20 Button Head Socket Screw
2	Headrest Bracket	2	M10 x 30 x 2.5 DIN Flat Washer
		2	M6 x 16 Flanged Hex Bolt G8.8



Time

30 minutes / Half a beer

For further information contact KAON on **07 3180 1470** or info@kaon.com.au

It all works together.

All our storage products work together, but there is a certain order to installing. Let's work out the best order for your setup, shall we?

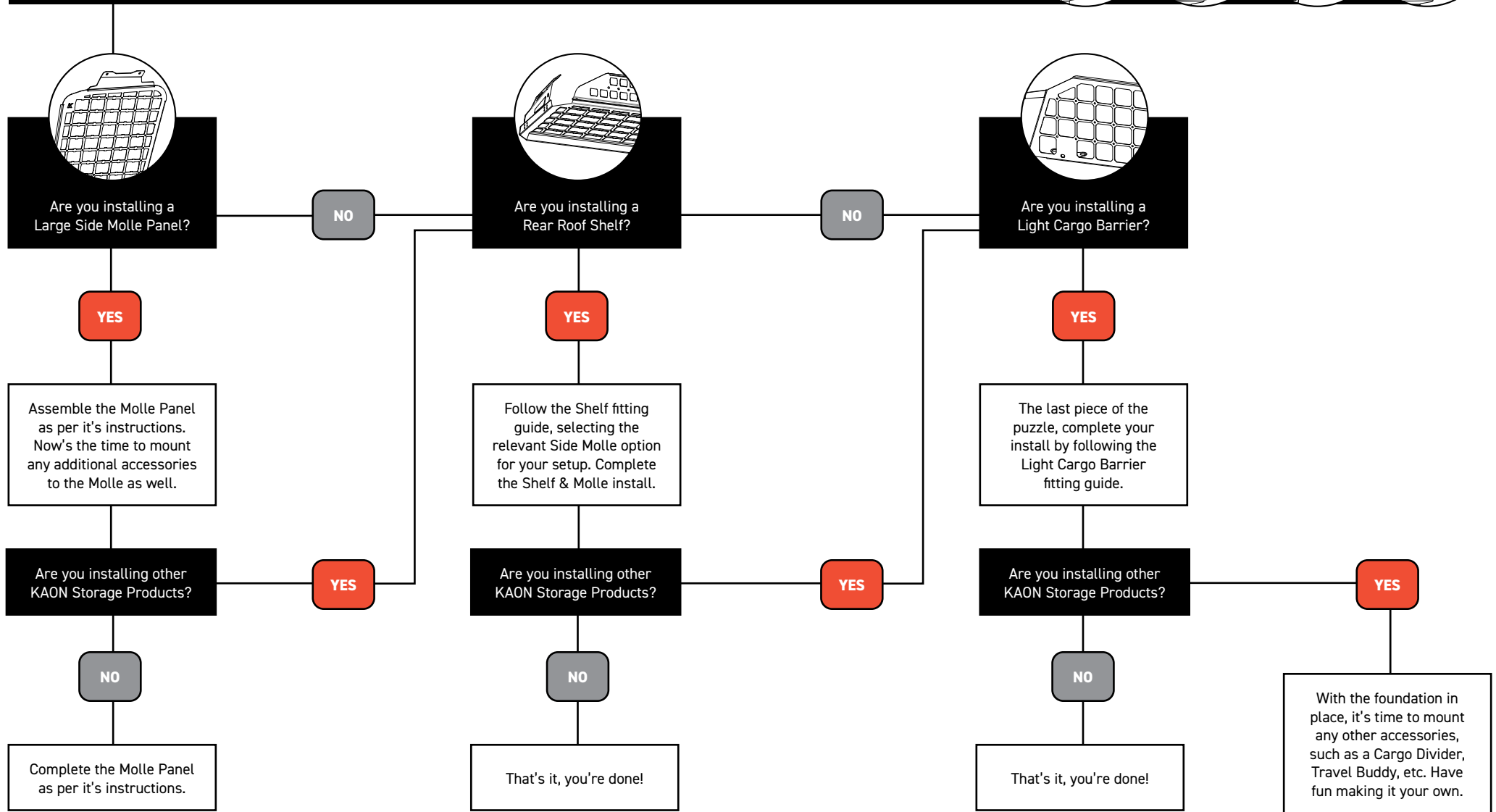
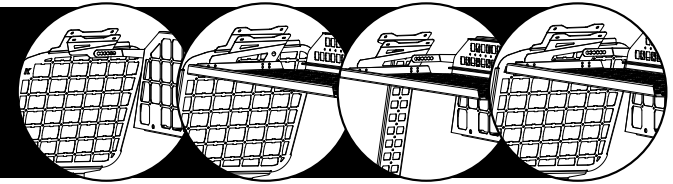

With your setup order sorted, let's get to the good part: installing. →

Let's get to work.

Preparing the Vehicle

1. Pry open the plastic covers on the rear grab handles with a small flatblade screwdriver or trim tool.
2. Use a 10mm socket to remove the rear handles. Set aside.



Installing the Brackets

To install the **Light Cargo Barrier**:

3. Align the handles with the cutouts in the handle brackets, then align the bolts and locating pins with the holes in the roof. Ensuring the nutsert is towards the roof, tighten to secure.
4. Replace trim caps.



To install **with Standalone Shelf and Side Molle Panels**:

5. Follow the instructions provided with the Standalone Shelf, then skip to step 6.

To install **with Side Molle Panels only**:

6. Ensure you have the correct panel for each side. The 'K' should be positioned at the back of the vehicle. If you're intending on mounting anything to the Molle Panel, it's easiest to do it now.
7. Place the feet of the Molle Panel into the rear cupholders. The feet are contoured to fit, and the rubber stoppers will keep it secure.
8. Sandwich the Cargo Barrier handle brackets over the Molle handle brackets. Align the handles with the cutouts in the brackets. Reinstall the handle brackets by tightening to secure.
9. Make any necessary adjustments to the panel. While applying downwards pressure to the panel, tighten all bolts.
10. Repeat on the other side.



Assembling the Barrier

11. Attach the barrier brackets to the barrier using the M6 bolts and wave washer. When installed, the barrier brackets should look as pictured.



Installing the Barrier

12. Remove the head rests and slide on the head rest brackets. Re-install the head rests with brackets in place.
13. Position the main barrier against the head rests. The flanged edge on the barrier should be directed forwards, and the warning stickers should be visible from the rear of the vehicle.
14. Loosely secure it to the head rest brackets using the M10 domed head bolts and M10 washer.
15. Attach the barrier bracket to the handle bracket nutsert using the M10 knob. You can adjust the position of the barrier by selecting the most suitable hole in the handle bracket.
16. Once the barrier is in the desired position, tighten all bolts and knobs securely. That's it, you're done! The barrier can be quickly removed by removing the plastic knobs and lifting out the head rests.



NOTICE

This barrier has not been tested to Australian Standards, and is intended as a pet barrier or for use when off-road. We cannot confirm compatible fitment of the this barrier with child restraints, due to the number of possible variations. Whilst it may work with your configuration, we recommend the use of a seat belt protector where any contact occurs between any seat belt or restraint and the barrier.

Bolt Torque

DIAMETER (mm)	5mm	6mm	8mm	10mm	12mm
NEWTON-METRES (Nm)	5 Nm	9 Nm	22 Nm	44 Nm	77 Nm



Local Knowledge & Assistance

We know half the fun of building your dream 4x4 is getting your hands dirty. But we also know that sometimes, things don't go to plan. If in the pursuit to build the ultimate setup you find yourself off-track, we're here to help you get unstuck.

For further information call 07 3180 1470 or email info@kaon.com.au

Disclaimer: The products sold by KAON should not be modified, and are for use only on the vehicles specifically stated. KAON will not be liable for any damages arising out of the use or misuse of it's products. It is the customers responsibility to ensure the products are safely and properly used and installed. KAON consistently seeks to improve it's products and reserves the right to make changes to any product.