



FITTING INSTRUCTIONS FOR

High Performance X700 UVP

SKU

KS0533/534/535

COMPATIBILITY

Toyota HiLux N70

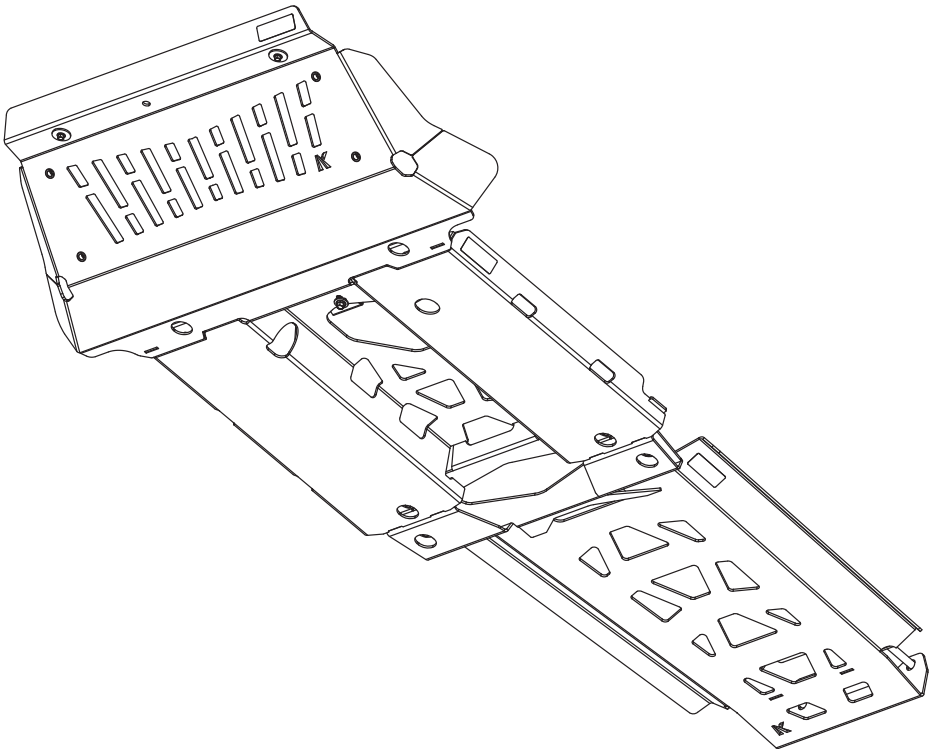

Scan the **QR code** to watch the video installation guide,
or for further information contact KAON on **07 3180 1470** or **info@kaon.com.au**



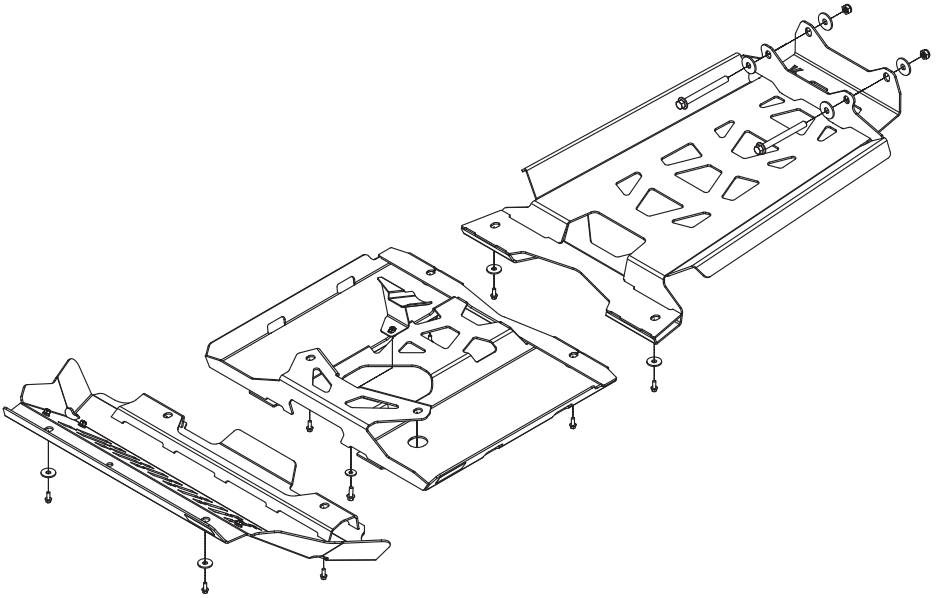

Front & Sump Guards included contents				KS0533/535	
QTY	COMPONENT	QTY	COMPONENT		
1	Front Guard	1	M6 x 16 Flanged Hex Bolt G8.8		
1	Sump Guard	1	M6 X 18 X 1.6 DIN Flat Washer		
1	Oil Drain Ramp	8	M8 x 25 Flanged Hex Bolt G8.8		
		8	M8 x 24 x 2.0 DIN Flat Washer		

Transmission Guard included contents				KS0534	
QTY	COMPONENT	QTY	COMPONENT		
1	Transmission Guard	2	M10 Nyloc Nut		
2	M10 x 110 Hex Bolt	2	M8 x 25 Flanged Hex Bolt G8.8		
4	M10 x 30 x 2.5 DIN Flat Washer	2	M8 x 24 x 2.0 DIN Flat Washer		

	Time	60 minutes / One beer
---	------	-----------------------

Let's get to work.

Preparation

The following instructions will vary depending on the UVP configuration you have opted for (Front & Sump, Transmission only or the full set).

1. Undo bolts that attach the splash guard to the front guard. If you plan to keep the splash guard installed hold onto these bolts, we'll reuse them – they are high quality and the discreet.
2. Remove all the factory under vehicle protection guards. Note that if you have not opted for our Transmission Guard, you can leave the rearmost deflector guard in place.
3. Ensure all mounting surfaces are clean, free of dirt and grime, and put some grease or anti-seize compound in the mounting holes.



Sump Guard Installation

4. The first piece to go on is the sump plate. Using four M8 bolts and washers, loosely fit the sump guard.
5. Insert the oil drain ramp into the sump drain opening and manoeuvre into position.
6. Secure using the provided M6 bolt and washer as pictured. Once installed, you should still be able to get a socket onto the drain plug head without fouling on the ramp.

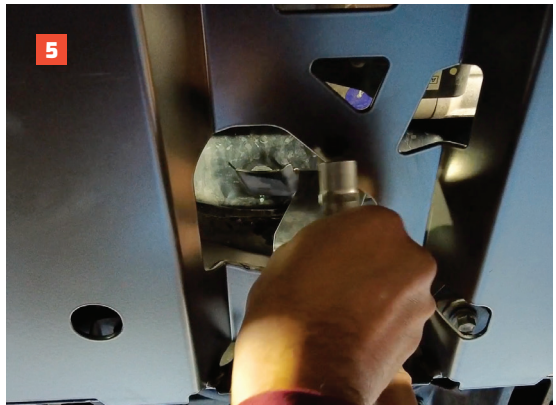
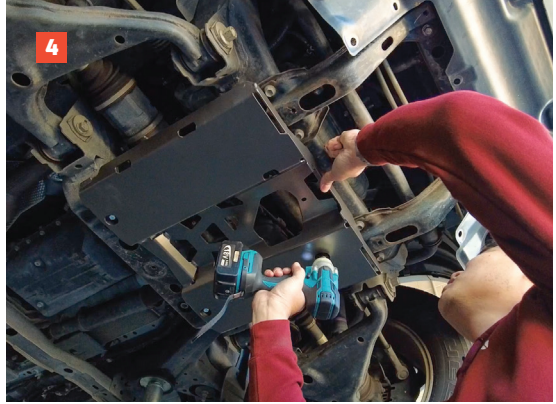

Front Guard Installation

7. Lift the guard into position, aligning it to the sump guard with roughly a 3mm gap. If you have opted to retain the factory splash guards, ensure it is tucked underneath.
8. Loosely secure the front guard in place with the four provided M8 bolts and washers, starting with the back two mounts first.

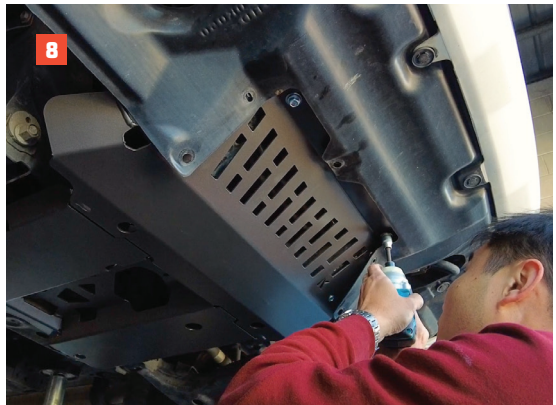

Transmission Guard Installation

9. Last piece to go on is the transmission guard. The back of the guard cradles the cross member, so line it up there first before loosely securing the front with two provided M8 bolts and washers.
10. Install the two provided M10 bolts with washers on the rear clamping section of the guard, ensuring they sit above the transmission cross member. Loosely secure each with another washer and nyloc nut as shown.
11. Tighten the clamping bolts, ensuring that where the transmission guard clamps is all the way up, sitting flush against the cross member.



Finishing the Install

12. That's all the fasteners installed! Check fitment and alignment of the plates, and adjust as needed.
13. Last up, tighten all the bolts as per the recommended torque settings.
14. If desired, reattach the plastic splash guards to the front guard nutserts, reusing the factory black M8 bolts. Note that the bottom of the splash guard may need to be pushed/pulled slightly into position.



Bolt Torque

DIAMETER (mm)	5mm	6mm	8mm	10mm	12mm
NEWTON-METRES (Nm)	5 Nm	9 Nm	22 Nm	44 Nm	77 Nm



Local Knowledge & Assistance

We know half the fun of building your dream 4x4 is getting your hands dirty. But we also know that sometimes, things don't go to plan. If in the pursuit to build the ultimate setup you find yourself off-track, we're here to help you get unstuck.

For further information call 07 3180 1470 or email info@kaon.com.au

Disclaimer: The products sold by KAON should not be modified, and are for use only on the vehicles specifically stated. KAON will not be liable for any damages arising out of the use or misuse of its products. It is the customers responsibility to ensure the products are safely and properly used and installed. KAON consistently seeks to improve its products and reserves the right to make changes to any product.