



FITTING INSTRUCTIONS FOR

Universal 270 Degree Awning Bracket Set

SKU

KS0465

COMPATIBILITY

**Rhino-Rack, Yakima & Rola Cross Bars;
Yakima LockNLoad Platform**

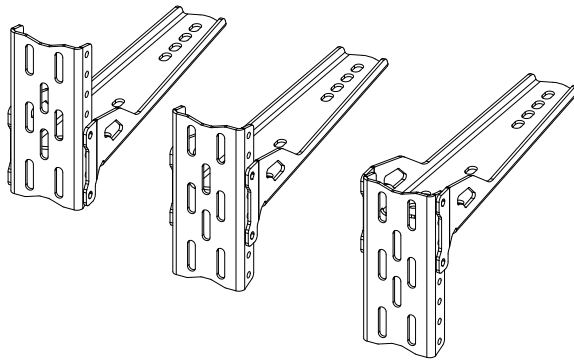

Included contents

QTY	COMPONENT
3	Roof Rack Bracket
3	Adjustable Awning Bracket
12	M6 x 12 Socket Head Cap Screw
12	M6 Nyloc Nut
9	M8 Tee Bolt
9	M8 Nyloc Nut
9	M8 DIN Washer

Also required (not included)

Hardware to mount Awning to Bracket
(Varies – generally 6 or 12 bolts and nuts)

A helpful mate (We couldn't fit one in the box)



Time

30 minutes / Half a beer

For further information contact KAON on **07 3180 1470** or info@kaon.com.au

Bolt Torque

DIAMETER (mm)	5mm	6mm	8mm	10mm	12mm
NEWTON-METRES (Nm)	5 Nm	9 Nm	22 Nm	44 Nm	77 Nm

Let's get to work.

Attaching the Adjustable Awning Bracket

1. It's best if we get the Awning Brackets attached to the awning first. Due to the sheer number of awning variations, we can't supply the hardware for this. So if you don't have the required hardware on hand, a trip to the shops may be in order.
2. First, confirm placement of the brackets. Starting with the outer brackets first, work out the desired spacing in relation to your racks overall length.

For platform style racks, brackets should be placed close to a cross brace or roof leg to minimise flex in the roof rack, and create the most direct load path. It's also worth placing the back two brackets further towards the back of the rack at the awning hinge. Twisting and lifting loads are higher at the corner and the brackets help brace and stabilise the roof rack. After this, confirm the height setting you want to use for the Adjustable Awning Bracket, so that it clears your vehicle setup.

3. Most awnings use a channel system, so insert the bolts into the channel and slide them into position. Each bracket requires either one or two bolts and nuts in the each channel.
4. Loosely tighten each, and check that the bracket is sitting square with the awning before tightening with a socket. Repeat for all 3 brackets.



Attaching the Roof Rack Bracket

1. Using the height setting we confirmed earlier, attach the roof rack bracket to the awning bracket using the provided socket head cap screws and nyloc nuts.



Installing the Awning

1. Position the 9 tee bolts in the roof rack channels, roughly in their final position / spacing.
2. **For platform style racks:**
We recommend two tee bolts in the outer channel, and one in the slot in the innermost hole, as pictured.
3. **For cross bar style racks:**
We recommend placing two tee bolts in the closest holes to the awning, and the other in the furthest, as pictured.
4. This is the part where you'll need a mate to help. Lift the awning into the desired position, and hold in place while loosely finger-tightening the screws into the slot nuts.
5. Once you've confirmed placement of the awning, use a socket to tighten. Ensure that the awning's weight is supported until all screws are secured.
6. That's it! All that's left to do is to head to the beach, open your 270° awning and enjoy the shade.





Local Knowledge & Assistance

We know half the fun of building your dream 4x4 is getting your hands dirty. But we also know that sometimes, things don't go to plan. If in the pursuit to build the ultimate setup you find yourself off-track, we're here to help you get unstuck.

For further information call 07 3180 1470 or email info@kaon.com.au

Disclaimer: The products sold by KAON should not be modified, and are for use only on the vehicles specifically stated. KAON will not be liable for any damages arising out of the use or misuse of its products. It is the customers responsibility to ensure the products are safely and properly used and installed. KAON consistently seeks to improve its products and reserves the right to make changes to any product.