



FITTING INSTRUCTIONS FOR

Reversing Camera Relocation Bracket

SKU

KS0382

COMPATIBILITY

Toyota FJ Cruiser

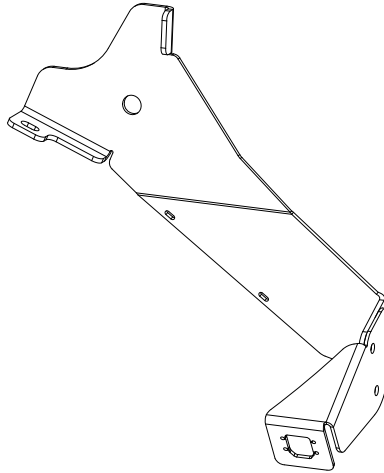

Included contents

QTY	COMPONENT	QTY	COMPONENT
1	Spare Tyre Mount Bracket	1	M6x16 Socket Head Cap Screw
1	Camera Bracket	1	M6 DIN Washer
1	M10x1.25 x 30 Hex Bolt G8.8	2	M6 Nyloc Nut
1	M10 DIN Washer	2	Small Cable Tie
1	M6x12 Socket Head Cap Screw		



Time

20 minutes / Half a beer

For further information contact KAON on **07 3180 1470** or info@kaon.com.au

Bolt Torque					
DIAMETER (mm)	5mm	6mm	8mm	10mm	12mm
NEWTON-METRES (Nm)	5 Nm	9 Nm	22 Nm	44 Nm	77 Nm

Let's get to work.

Preparation

1. To start with, remove the spare tyre and clean any dusty or dirty surfaces.
2. The camera is nested within a metal bracket using three M8 bolts, remove those with a 12mm socket.
3. Once removed, unplug the camera by pressing the clip as shown. If built-up dust makes it tough to remove, use a small screwdriver to lift the tab.
4. Free the cable from it's mounting position by locating the white clip at the base of the spare tyre mount. Push the tab as shown towards the door and the cable should come free.



Attaching the Camera

1. Remove the shroud and screws from the back of the factory camera bracket.
2. Attach the camera to the smaller supplied pivoting Camera Bracket, using the small screws removed earlier. Ensure that the serial number (top of the camera) faces the top of the bracket as shown, so your camera is the right way up.



Bracket Installation

1. Loosen all the bolts holding the spare tyre carrier, and remove the bottom right one altogether.
2. Position the Spare Tyre Mount Bracket under the bottom corner, ensuring the raised edges of the bracket sit firmly against the sides of the carrier. Use the supplied M10 Bolt and Washer to secure it in place.
3. Once in position, tighten all the bolts on the spare tyre carrier.

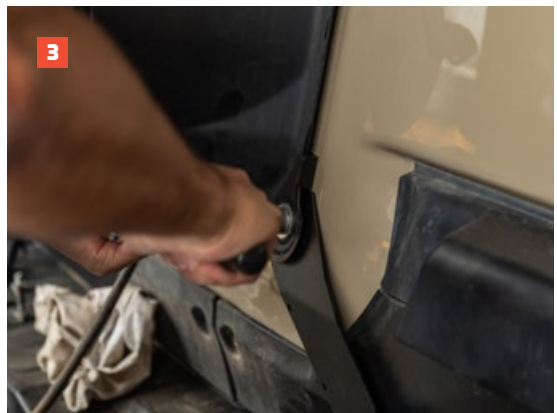

Camera Installation

1. Locate the small slot in the Spare Tyre Mount Bracket and insert the white clip you freed earlier, as pictured.
2. Loosely attach the Camera Bracket with the camera installed to the larger Spare Tyre Mount Bracket, using the Socket Head Cap Screws. Use the M6x12 and one Nyloc nut in the top hole, and the M6x16, M6 Washer and a Nyloc nut in the bottom hole slotted hole as pictured.
3. Plug the camera in.



Camera Installation cont.

4. Position the cable underneath the bottom edge of the bracket and secure in place using the supplied cable ties.
5. We'd suggest you re-attach the spare tyre before adjusting the angle and tightening the Camera Bracket, as the tyre will sit slightly within frame.
6. Once you're happy with the view, tighten the screws on the Camera Bracket.
7. You're all set! Now you don't need to do a Stevie Wonder impersonation when reversing with a bin bag fitted.





Local Knowledge & Assistance

We know half the fun of building your dream 4x4 is getting your hands dirty. But we also know that sometimes, things don't go to plan. If in the pursuit to build the ultimate setup you find yourself off-track, we're here to help you get unstuck.

For further information call 07 3180 1470 or email info@kaon.com.au

Disclaimer: The products sold by KAON should not be modified, and are for use only on the vehicles specifically stated. KAON will not be liable for any damages arising out of the use or misuse of its products. It is the customers responsibility to ensure the products are safely and properly used and installed. KAON consistently seeks to improve its products and reserves the right to make changes to any product.